



Prestige
STAIRLIFTS
— est. 2006 —

Which?
Trusted Trader

**PRESTIGE 130
STRAIGHT STAIRLIFT**

AT PRESTIGE STAIRLIFTS, WE ARE DEDICATED TO PROVIDING HIGH QUALITY, TAILORED STAIRLIFT SOLUTIONS TO HELP YOU REGAIN INDEPENDENCE AND MOBILITY IN YOUR HOME. WHILE OUR HISTORY IS ROOTED IN A COMMITMENT TO EXCEPTIONAL SERVICE, OUR FOCUS REMAINS FIRMLY ON OUR SPECIALISM IN DELIVERING RELIABLE AND SAFE STAIRLIFTS AND MAINTAINING AN EXCELLENT REPUTATION WITH OUR CUSTOMERS.

A family run business, established in East Sussex in 2006, today we have engineers working across the South East offering specialist stairlift services to customers in Kent, Surrey, Sussex and beyond.

We believe in a personalised approach, offering complimentary home surveys to accurately assess your specific requirements and provide a tailored quote. Our services extend beyond installation by our Trading Standards approved engineers to include comprehensive maintenance, prompt repairs and even a free removal service for eligible products.

OUR REPUTATION

Our dedication to excellence has earned us recognition and a strong reputation within the industry and among our customers. We are proud to be:

- A **Which? Trusted Trader**, an endorsement of our commitment to quality and customer service.
- Highly recommended by our customers on Which? Trusted Traders, achieving a **100% recommendation rate** from over 120 reviews and an average rating of **5.0 for customer service, quality, and value.**
- **5 Star Rated on Google.**
- **Trading Standards Approved**, demonstrating our adherence to the highest standards of trading practices.
- Accredited with the **British Healthcare Trades Association (BHTA)** and **Checkatrade**, further highlighting our credibility and reliability.

0800 032 9972 | www.prestigestairlifts.co.uk

WHAT OUR CUSTOMERS SAY

“Excellent service - highly recommended”

I was recommended Prestige from a neighbour who recently had an installation. I can absolutely forward that recommendation - the team at Prestige have been brilliant. From my initial enquiry, through to the technical measurement and installation, all very smooth. They also came in about 20% cheaper than an alternative supplier. I had a question post-installation that the team answered quickly - you can tell they genuinely wanted to delight their customers. Making the decision to install a stairlift is a big one and one that we may not look forward to having to make - Prestige make the whole process as easy as possible.

Stairlift installed for a customer in Kent

“First class service”

I called Prestige early this morning and left my details. Straight away I received a call back from Charlotte who then arranged for someone to visit my nan and assess her stairlift. Tim attended my nan's almost straight away and mended the stairlift. The service from Prestige has been excellent and nan and I really appreciated such a speedy response. I would 100% recommend Prestige. Thank you very much.

Stairlift repaired for a customer in East Sussex

“Phoned to make an appointment for a stairlift to be fitted. On Tuesday a nice young man called Tim came round, he phoned to let us know he was on his way, he gave us good advice and prices on suitable stairlifts for us, there was no hard sell or pressure to buy. We decided to go for a new one and asked him how soon it could be fitted. He said he could do it on the Thursday, once again he phoned to say he was on his way. Once fitted he explained how it all worked and made sure we were happy. Would highly recommend Prestige.”

Stairlift installed for a customer in East Sussex

“One very happy 92 year old man, with new legs for getting up and down the stairs by himself. Fantastic job from Peter, Callum and Kris. Thanks a million, would highly recommend their great, efficient service.”

Stairlift installed for a customer in West Sussex

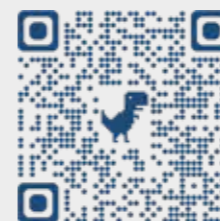

These examples offer a glimpse of the positive feedback we consistently receive. Please scan the QR code here to view additional customer testimonials.

BECAUSE EVERY STAIRCASE IS DIFFERENT, PRESTIGE STAIRLIFTS HAVE BEEN DEVELOPED TO BE HIGHLY ADAPTABLE

Do you have a straight staircase?

If your staircase consists of one complete flight of stairs leading to a top landing or hallway, with no middle landing, you may require a **Prestige 130 Straight Stairlift**.

The simplest solution for a straight staircase, the Prestige 130 Straight Stairlift uses a single rail attached to your staircase.

Its unique slimline design ensures that there is plenty of space left for other members of the family to use the stairs.



A Prestige Stairlift blends seamlessly into your home, and the smooth start and stop mechanism allows you to glide effortlessly up and down the stairs.

THE PRESTIGE 130 STRAIGHT STAIRLIFT

Welcome to the **Prestige 130 Straight Stairlift**. A slimline, safe and comfortable stairlift, built to last, with low maintenance and high reliability.

It runs on maintenance free DC power packs, which are automatically recharged at the end of every trip. This type of power ensures that the stairlift is safe to use and incredibly smooth.

At Prestige Stairlifts, we truly understand how vital it is for you to enjoy your home and maintain your mobility and dignity. Installing a stairlift is a practical solution that ensures quick installation time and no structural damage. We believe that everyone deserves to feel comfortable and independent in their living space. Whenever we install a stairlift, we can help you reclaim your entire home.



Features:

- Slimline design.
- Runs on maintenance free rechargeable batteries. Works even in a blackout!
- Numerical fault code display for easy diagnostic and repair guidance.
- Weight capacity 19 stones (120kg).
- Heavy Duty option available up to 25 stones (159kg).
- No unsightly structural work needed – fits directly to your stair treads rather than the wall.

The swivel seat means that there is no need to twist awkwardly when rising from the stairlift at the top of the stairs and acts as a safety barrier.



The Prestige 130 straight stairlift:

Engineered for discretion and practicality. Its slimline design ensures it remains neat and tidy on your staircase, folding away unobtrusively so others can use the stairs with ease.



The commitment to a minimal footprint means the Prestige 130 does not compromise the aesthetics or functionality of your hallway. It offers the perfect balance of safety, independence, and discrete integration, allowing the user to navigate their home safely and comfortably without disrupting the flow or design of their interior.



The Prestige 130 Stairlift offers seamless integration, demonstrating that enhanced accessibility can be achieved without compromising a property's aesthetics or structural integrity. The track is securely installed on the stair treads, bypassing the need for wall attachment and thus ensuring zero structural damage. Furthermore, its intelligent fold-away mechanism maintains minimal obstruction, allowing other users to navigate the staircase with ease. This solution elegantly combines independence with domestic flow.



Beyond ease of use, the Prestige 130 delivers a superior ride quality. Its advanced mechanics result in a consistently smooth journey, eliminating jolts and abrupt movements.

THE PRESTIGE 130 STRAIGHT STAIRLIFT FEATURES AND BENEFITS



Safety belt

A safety belt is fitted to all Prestige Stairlifts, so you feel secure at all times.



Safety cut-out sensors on carriage and footrest

Safety sensors on the footrest and carriage stop the lift automatically and very gently should there be any obstruction on your staircase.



Safety lock

A lockable on/off switch provides additional "child friendly" safety.



Simple to use controls

Directional toggle switches give you complete control. They can be operated easily should you have limited dexterity.



Digital display

A simple digital display allows you to see the exact status of the stairlift at all times.



Slim fold away design

The arms, seat and footrest all neatly fold away. With its ultra slimline design there's plenty of room for other users of your staircase.



Wireless remote control

Two remote controls are provided so that you have the convenience of being able to call or send the lift up or down the staircase.



Swivel seat locks in either 45° or 90° position

A lockable swivel seat means you can get on and off your stairlift without twisting your body. Once turned it also provides a stable base and safety barrier at the top of your stairs.

ADDITIONAL OPTIONS AVAILABLE



Hinged Rail*

In situations where there may be an obstruction at the foot of the staircase (usually a door), or where the stairlift could cause a tripping hazard, a hinged rail is required to 'fold back' away from the obstruction when the stairlift is not in use.

Powered Hinge Rail*

The rail is available with a powered hinge. The track folds up at the bottom automatically to eliminate any potential tripping hazards.



Powered Swivel Seat

For enhanced safety and ease, the optional powered swivel simplifies getting on and off your stairlift. Upon reaching the top of your stairs, the seat automatically and gently turns to face the landing, removing the need for manual effort.



Powered Footrest*

A powered footrest allows the user to automatically lift the footrest when in the parking position.

Heavy Duty Stairlift

For users up to 25 stone (159kg) with a wider seat option and heavy-duty batteries.

Outdoor Stairlift

Fully weather-proofed, ideal for outdoor use. With all the same features as the Prestige 130 Straight Stairlift. Supplied with a durable waterproof cover for extra protection.

**Not available on outdoor or heavy duty stairlifts.*

PRESTIGE 130 STRAIGHT STAIRLIFT SPECIFICATIONS

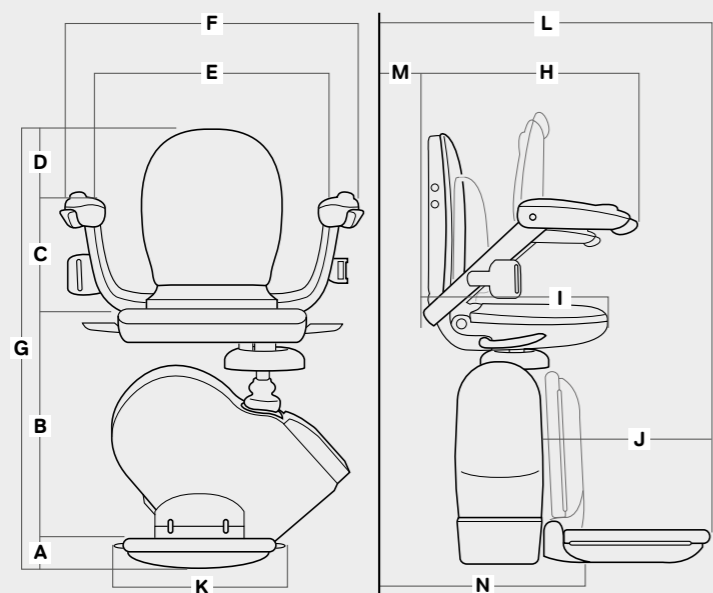

Dimensions

	mm	inch
A Floor to top of footrest	95	3¾
B Top of footrest to top of seat	445	17½
C Top of seat to top of arms	250	9¾
D Top of arms to top of seat back	190	7½
E Width between armrests (wide arm version)	445 (495)	17½ (19½)
F Overall width	605	23¾
G Overall height	980	38½
H Length of arms from seat back	470	18½
I Length of seat base from seat back	435	17
J Length of footrest	325	12¾
K Width of footrest	310	12¼
L Front of footrest to stringer	570	22½
M Back of seat to stringer	13	½
N Folded depth	310	12¼

Measurements are only a guide and subject to site and client survey.

Specifications

Motor Output Speed

No greater than 0.15 m/s

Method of Drive

Rack and Pinion

Power Supply

24v DC (battery)

Maximum Capacity

127kgs

Track Extruded

Aluminium

Mains Supply

120 - 240v AC

OUR SIMPLE, STRESS FREE PROCESS

The first step towards getting a stairlift is our **free, no-obligation home survey**.

When you contact Prestige Stairlifts, we will schedule a visit from one of our fully trained Stairlift Engineers. They will discuss your needs, survey your staircase, and provide you with a comprehensive, no-obligation quotation.

Expert Advice, never high-pressure sales

Because we use only our own experienced engineers, not sales representatives, you can be sure you're getting the best expert advice without any pressure to commit.

Your Prestige Stairlift Installation

If you decide to proceed with your Prestige Stairlift, we will quickly schedule your installation date. This can often be as fast as the same or next day but is usually completed within a week.

Our engineer will arrange a precise and convenient time for their arrival.

The installation is a quick, clean, and straightforward process, typically finished within just a couple of hours. Since the stairlift is fitted directly to the stair treads rather than the wall, there will be no structural damage.

After fitting, the engineer will provide a full demonstration of the stairlift operation to ensure your complete satisfaction.

Prestige Stairlifts Aftercare and Guarantee

We provide comprehensive aftercare for all our stairlifts, ensuring continued support and peace of mind.

Our Guarantee:

- **New Stairlifts:** Come with a 2-year guarantee.
- **Reconditioned Stairlifts:** Include a 1-year guarantee.

Please refer to our Warranty and Service Cover leaflet for more information.

24/7 Support:

Our friendly, local engineers, accredited as Which? Trusted Traders are available 24 hours a day, 365 days a year. This continuous standby service ensures that in the rare event of a fault, an experienced professional can carry out a repair promptly, supporting you year-round.

0800 032 9972 | www.prestigestairlifts.co.uk

Prestige

STAIRLIFTS



Offices throughout the South East of England

Call us on 0800 032 9972

www.prestigestairlifts.co.uk



Proud members of
Checkatrade.com
Where reputation matters

