



Straight

Custom Built Comfort



www.prestigestairlifts.co.uk

THE LINCOLN STRAIGHT STAIRLIFT

FEATURES

- Slimline design.
- Runs on maintenance-free rechargeable batteries. Works even in a blackout!
- Numerical fault code display, for easy diagnostic and repair guidance.
- Weight capacity 19 Stones (120Kg).
- No unsightly structural work needed - fits direct to your stair treads rather than the wall.



OPTIONS

- Powered swivel and footrest options
- Lever linked footplate option
- Foot cover option
- RF remote control
- Bariatric option available up to 160kg (25st)
- ERGO Space seat for narrow staircases, saves 60mm with a standard ERGO seat pad or 85mm with an ERGO Plus seat pad.

Our straight stairlifts are built to last, with low maintenance and high reliability. They run on maintenance free DC power packs, which are automatically recharged at the end of every trip. This type of power ensures that the stairlifts are safe to use, and are incredibly smooth.

SAFE AND EASY

Prestige Lincoln straight stairlifts come with all the necessary features and a few extra ones, as standard. Thanks to all of the available features, the Prestige stairlift is safe, comfortable and easy to use.

- Soft start and stop system - no sudden jolts
- Easy to use joystick control
- Remote control system - means no messy wiring
- Low voltage operation - eliminates risk of shock
- Electro mechanical braking with failsafe overspeed governor
- Delivered fast - delivered in days, fitted in an hour



The Lincoln straight stairlift



THE PRESTIGE LINCOLN STRAIGHT STAIRLIFT



2

Wireless Remote Control

The lift can be 'called' or 'sent' up or down the stairs when ever it's needed, making it easy for multiple users to control the stairlift



3

Safety cut-out sensors on carriage and footrest

If anything is blocking the progress of the Stairlift, it will come to an immediate halt. There are 5 sensors: 3 on the footrest, and 2 on the carriage.



1

Folding arms, seat and footrest

The arms, seat and footrest all neatly fold away. With its ultra slimline design there's plenty of room for other users of your staircase.

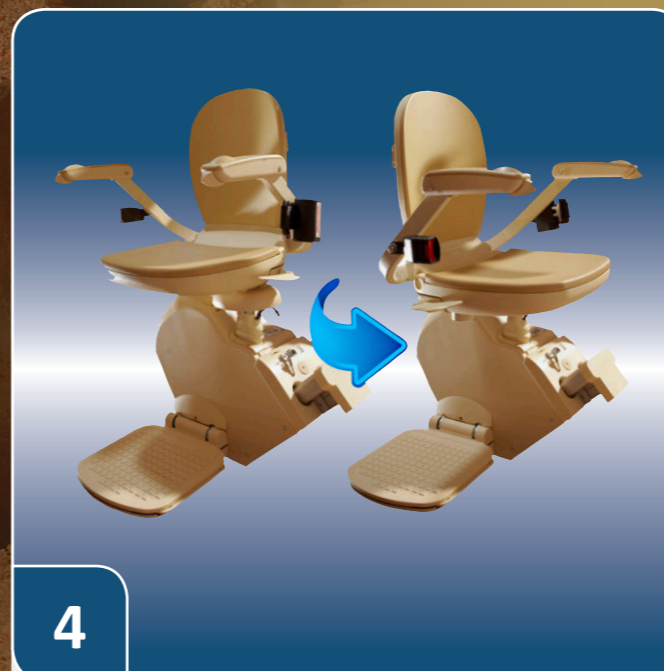

4

Swivel seat, locks in either 45° or 90° position

The seat turns and locks in either a 45° or 90° position, helping you get in and out of your stairlift, easily and safely.



5

Simple to use controls

Using the lift is as easy as pushing the armrest paddle in the direction of travel.

OUR SERVICE

Prestige provide speedy and reliable back-up and maintenance service to make sure you are happy with your stairlift, and remain so. In the unlikely event of a breakdown, one of over 20 customer care engineers that we have nationwide will come to you as quickly as is possible, often on the same day. This large number of customer care engineers ensures that customers aren't stranded without their stairlift for long periods of time. All stairlifts are designed to comply with BS5776 and BS5900 standards. This ensures that our stairlifts remain safe and reliable.

MAINTENANCE

All Prestige stairlifts come with a guarantee for a period of 12 months from the installation date. The guarantee covers all replacement parts and labour charges, should you stairlift need to be repaired through mechanical or electrical failure.

We recommend that you have your stairlift serviced once each year by Prestige' fully trained engineers. This ensures that your stairlift will be fully functioning and safe for use for a long time to come.

ONSITE SURVEY

Due to the fact that your Prestige stairlift will be built specifically to the requirements of your stairs, Prestige will happily send out one of their fully trained consultants to your home to discuss your stairlift requirements.

Whilst they are there, they will also carry out a no-obligation survey so that you will be able to get a quote for a stairlift and purchase one in your own time.

GUARANTEES AND WARRANTIES

All Prestige straight stairlifts are guaranteed for a period of 12 months from the installation date. The guarantee covers you for all mechanical failures through defects in manufacture of the straight stairlift.

EXTENDED WARRANTY

You can purchase an extended warranty covering all parts and labour charges for up to a further four years after the 12 month guarantee ends. This scheme is our Golden Care Warranty Programme; to find out more about this scheme, simply ask one of our sales consultants. To take advantage of the extended warranty cover, it should be purchased at the time of installation or up to 12 months after installation.



SPECIFICATIONS

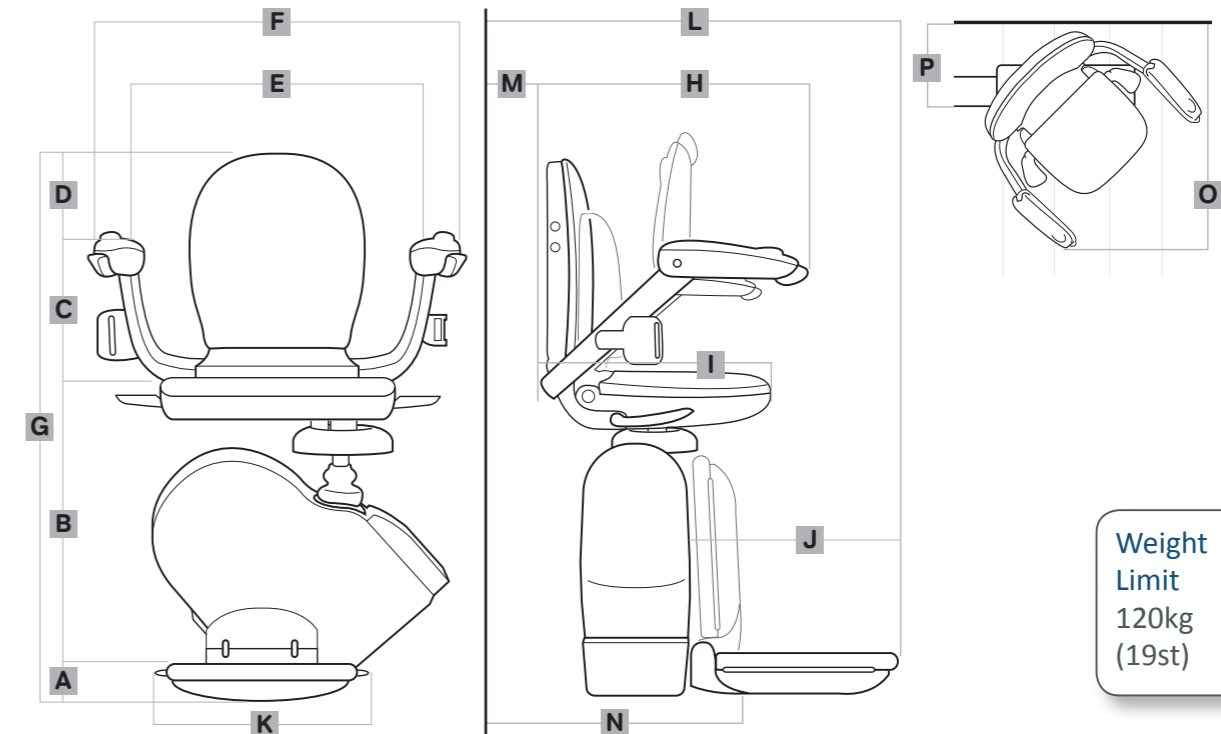

Dimensions

	mm	inch
A Floor to top of footrest	85	3½
B Top of footrest to top of seat	455	18
C Top of seat to top of arms	250	10
D Top of arms to top of seat back	250	10
E Width between armrests (Wide arm version)	445 (495)	17½ (19½)
F Overall width	620	24½
G Overall height	975	38½
H Length of arms from seat back	470	18½
I Length of seat base from seat back	425	16¾
J Length of footrest	325	12¾
K Width of footrest	310	12¼
L Front of footrest to stringer	546	21½
M Back of seat to stringer	13	½
N Folded width	280	11
O Minimum width required to swivel at top	645	25½
P Distance from front of rail to stringer (Wide arm version)	210 (235)	8¼ (19¼)

Power supply input range 90-264 VAC
Carriage power 24 Volt DC batteries

Measurements are only a guide and subject to site and client survey.

5692/BRSDS/1213



Proud members of
Checkatrade.com
Where reputation matters



ISO9001 FM92469



www.prestigestairlifts.co.uk

UK Curve 07/2015
© 2015 Prestige Stairlifts Limited